

DET 1

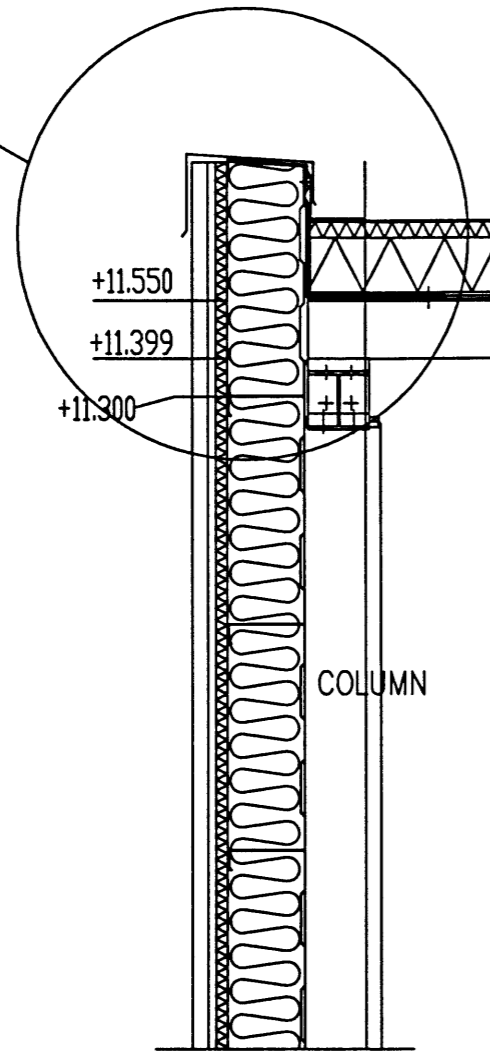

DET 1, 1:10

SAMÞYKKT AF BYGGINGARFULLTRUA

07.11.2000

BYGGINGARFULLTRUINN Í VESTMANNAEYJUM

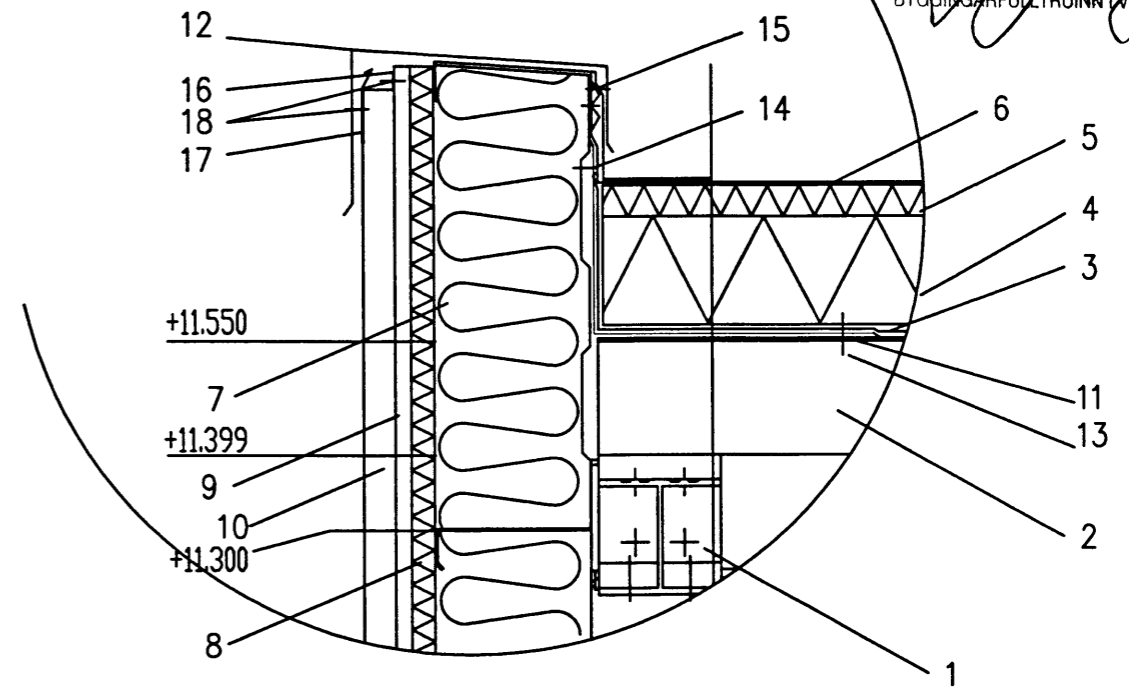

- 16 STEEL SHEET, t= 12 mm, PVF2-COATED
- 17 STEEL SHEET, t=12 mm, PVF2-COATED
- 18 FASTENING SCREWS, SX6/6-S16-5.5*26, cc 400 mm
980 PCS

- 1 STEEL STRUCTURE
- 2 PROFILED STEEL SHEET, RANNILA 153/
- 3 VAPOUR BARRIER
- 4 MINERAL WOOL, 140 mm
- 5 MINERAL WOOL, 40 mm
- 6 WATER ISOLATION
- 7 RANNILA CASSETTI 200
- 8 WIND BARRIER, MINERAL WOOL, 30mm
- 9 HAT PURLIN, 20x50x20, t=12 mm
- 10 RANNILA FASETTI,
- 11 STEEL SHEET, t=12 mm
- 12 STEEL SHEET, t=12 mm
- 13 FASTENING SCREWS, SL3-H15-6 3*32 cc 400 mm, 490 PCS
- 14 FASTENING SCREWS, SL3-H15-6 3*32 cc 400 mm, 490 PCS
- 15 FASTENING SCREWS, SL3-H15-6 3*32 cc 400 mm, 490 PCS

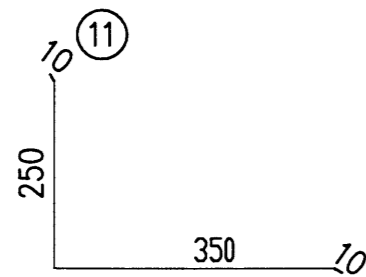

STEEL SHEET 12mm 97 m

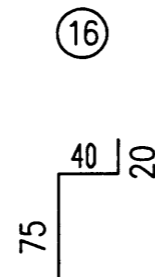

STEEL SHEET 12mm 97 m

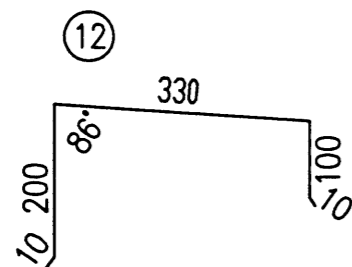

STEEL SHEET 12mm 97 m

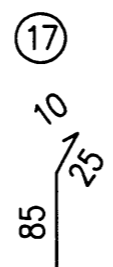

STEEL SHEET 12mm 97 m

REV NO	REV MARK	REVISION DESCRIPTION	ISSUE DATE
DRAWING TITLE		EAVES 1-2 - 16-17 / R AND 16-17 - 1-2 / R	
CONTRACT		Rannila Steel Dy	
MODELLED BY		ISSUE DATE	26.09.2000
CONTRACT NO		36-0402	SCALE 1/20